



Build With Purpose

Installation, Operation & Maintenance Instructions for the PRIER P-RH1, 2, 3 Heavy Commercial Roof Hydrants and Bracket

Please leave this sheet for the property homeowner

The PRIER Heavy Commercial Roof Hydrants provide a wide variety of installation options suitable for all types of roofs and structures. The PRIER Universal Roof Hydrant Mounting Bracket (P-RMB) attaches to a structural member of the building, not simply the skin of the building, to provide a stronger, safer installation. Additionally, if the hydrant is installed through a small, single hole penetration in the roof, ensuring simple installation by a single tradesman and years of leak-free operation. The PRIER design is adjustable for all types of roofs up to 2/12 pitch.

Depending on your installation, standard building materials may be required, including Unistrut, threaded rod and additional fasteners.

TYPICAL INSTALLATIONS

Truss (Purlin) Installation

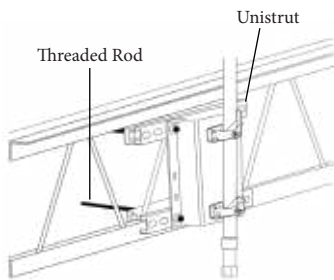

I-Beam (Column) Installation

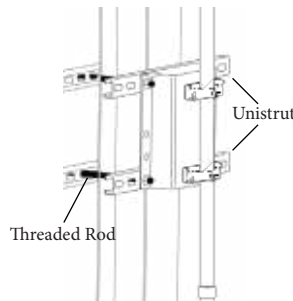

Concrete Roof Installation

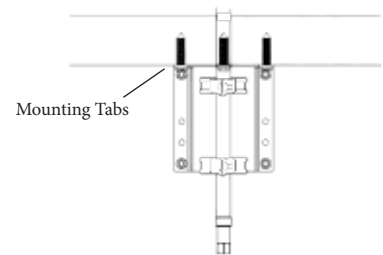

BRACKET INSTALLATION INSTRUCTIONS

1. Select a location for the installation of your PRIER Roof Hydrant. A good location is near rooftop equipment requiring water and within proximity of structural members under the roof.
2. Determine the type of installation you will use to install the Universal Roof Hydrant Mounting Bracket (P-RMB) to the structure of the building. Typical installations are shown above. The P-RMB can be installed on any of the structural supports on the building. * Some installations may require additional strut, threaded rod, and fasteners.
3. If mounting to a concrete roof, assure that the vertical mounting tabs are in the “UP” position.
4. Mount the P-RMB to the desired structure.

Truss (Purlin) Installation Instructions:

1. For a truss installation, you will need to use the strut and fasteners that are not provided with the P-RMB.
2. Cut two sections of the strut that are approximately 24” in length, making sure the strut is long enough to cover enough of the webbing to ensure a secure connection. Using threaded rods, secure the strut pieces on either side of truss (purlin).
3. Mount the P-RMB to the struts using the ½” bolts provided.

I-Beam (Column) Installation Instructions:

1. For a column I-beam installation, you’ll need to use strut, threaded rod, washers and nuts that aren’t provided with P-RMB.
2. Cut four sections of the strut that are approximately 8” longer than the width of the I-beam. Using threaded rods, secure the strut pieces on either side of the I-beam.
3. Mount the P-RMB to the strut using the ½” bolts provided.

Concrete Roof Installation Instructions:

1. For a concrete roof, use ½” concrete wedge anchors, not provided with the P-RMB.
2. Using the top tabs on the P-RMB as a template, mark the concrete where the holes for the concrete wedge anchors should be drilled. Drill and install concrete wedge anchors per manufacturer’s instructions.
3. Mount the P-RMB to the wedge anchors installed in step two and torque to manufacturer requirements.



Installation, Operation & Maintenance Instructions for the PRIER P-RH Heavy Commercial Roof Hydrants and Bracket

Please leave this sheet for the property homeowner

ROOF PITCH OPTIONS

In some occasions, the roof hydrant may need to be angled to match the roof or equipment configuration. These adjustments have been accounted for in the P-RMB design.

As shown in Figure 1, the angle of the roof hydrant can be adjusted by changing the position of the strut channel according to the pitch of the roof. Simply loosen or remove the bolt securing each of the strut channels to the P-RMB.

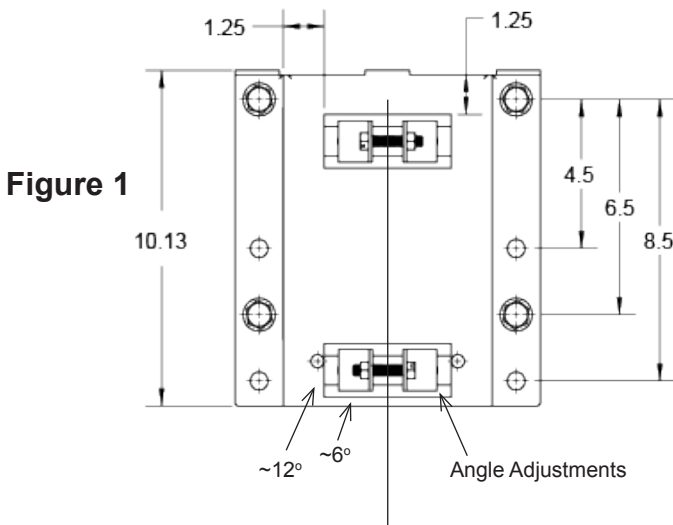
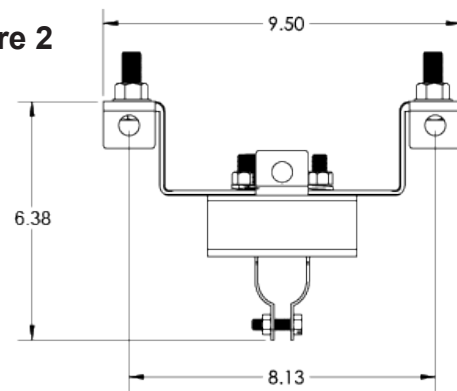

Figure 2



HYDRANT INSTALLATION INSTRUCTIONS

1. Loosely install the pipe clamps and mark the roof directly above the pipe clamps. Use a laser pointer, weight and string or scrap pipe through the pipe clamps to ensure the hole is marked in the proper location. Using a long 1/4" drill bit, drill a small pilot hole through the roof. Insert a rod through the roof extending through the loosely mounted pipe clamps to ensure proper location. If there is misalignment, re-drill pilot hole. Drill a 1 3/4" hole through the roof at the marked location.
2. Install the hydrant from the rooftop through the hole drilled in step one and down through the pipe clamps in the P-RMB. Each hydrant has a measuring tape sticker affixed to the hydrant to assist in installation. The measuring tape begins at "roof level". You will need to take into account any insulation, pitch boxes or gravel when determining the height of the hydrant.
3. Secure the hydrant into the P-RMB by tightening the bolts through the pipe clamps, make sure to rotate the hydrant to the desired orientation before tightening.
4. If using a freezeless hydrant, there is a 1/8" drain port that will need to be piped away to a drain.

ROOF SEAL

The roof penetration should be sealed by the roofing contractor with acceptable roofing construction methods. PRIER recommends either a poured in place pitch box or a leaded roof flashing, sealed by the roofing contractor, as they would for any other rooftop pipe penetrations.

MAINTENANCE

The PRIER Roof Hydrants require no scheduled maintenance and will provide years of reliable service.



Build With Purpose

P-RMB Universal Mounting Bracket



PRIER's P-RMB Universal Roof Hydrant Mounting Bracket provides a secure way to attach any 1" or 2 1/2" pipe to a roof structure, thus providing a simple water source on the roof of a building. PRIER's Mounting Bracket is compatible with any roof hydrant, including PRIER's P-RH1, P-RH2, P-RH3 and P-RH4 Commercial Roof Hydrants.

The Roof Mounting Bracket enables the hydrant to be mounted to any structural frame of a building with rigid support, unlike other brackets which attach to the skin of the building.

This bracket requires only a single penetration point of 1 3/4" or 3 5/8", and can be mounted to concrete, wood, steel, I-beams, truss, perlins or other structural members with standard construction materials (Unistrut, threaded rods, or other).

- **Mounts To Any Roof Structure**
- **Single Hole Penetration**
- **Works w/ Any 1" or 2 1/2" Pipe**
- **Powder Coated Steel Design**

FEATURES

- Mounts to structure beneath roof surface for more secure installation
- Includes 1" and 2 1/2" conduit clamps to secure hydrant to bracket
- Mounts to any roof structural member (truss, I-beam, concrete roof, or other)
- Compatible with PRIER's P-RH1, P-RH2, P-RH3 and P-RH4 roof hydrants
- Single hole penetration of 1 3/4" (P-RH1, P-RH2, P-RH3) or 3 5/8" (P-RH4)
- Single person installation with standard tools
- Bracket can be installed during or after construction of building
- Designed to be installed with standard construction materials (Unistrut, threaded rods, or other)
- Seals with standard roofing materials or rubber flashing products
- Works with any 1" or 2 1/2" pipe
- Powder coated steel design
- Bracket struts are adjustable to accommodate roof angles up to 2/12 pitch or 9°
- Works with any roof hydrant

ORDERING

Part No.	Description
P-RMB	Roof Hydrant Mounting Bracket



Build With Purpose

P-RMB REPLACEMENT PARTS AND STEMS

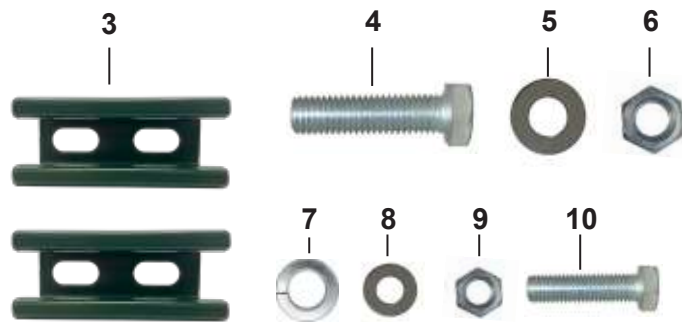
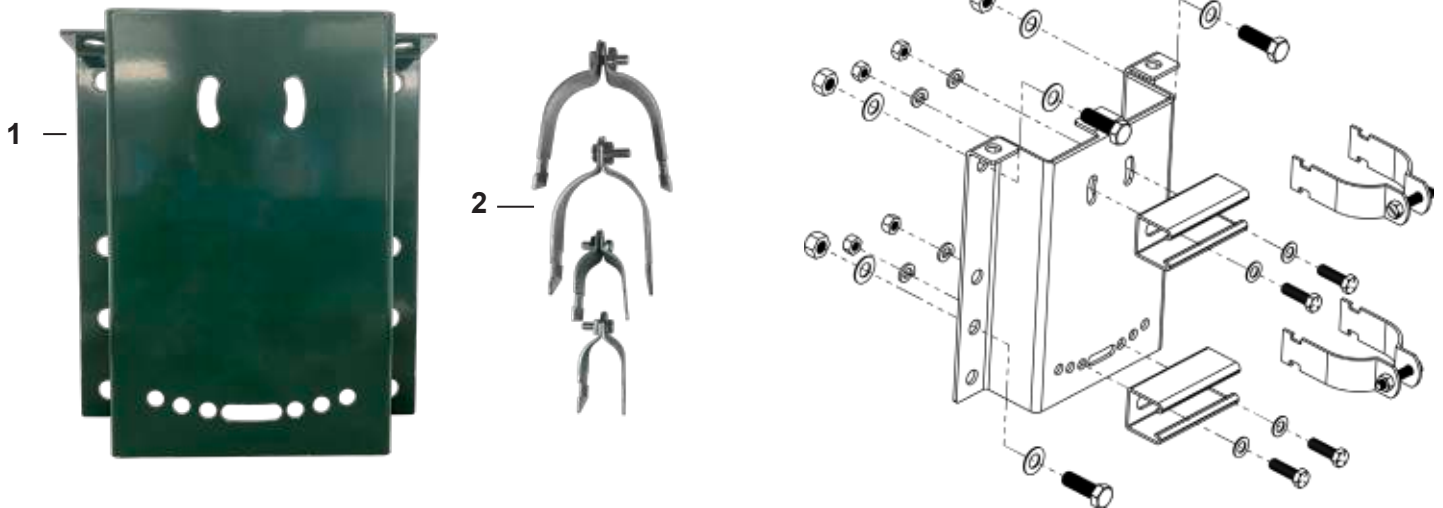

ID	Part No.	Description
1	314-0021	Mounting Bracket
2	399-7002	1" Pipe Clamp Assembly for P-RH1, P-RH2, P-RH3
2	399-7003	2 1/2" Pipe Clamp Assembly for P-RH4
3	314-7012	Unistrut Steel Struts
4	314-0028	1/2" Mounting Bolt
5	314-0029	1/2" Flat Washer
6	314-0030	1/2" Mounting Nut
7	314-0025	3/8" Lock Washer
8	324-1003	3/8" Flat Washer
9	314-0027	3/8" Hex Nut
10	314-0035	3/8" Bolt

ROUGH-IN DIMENSIONS

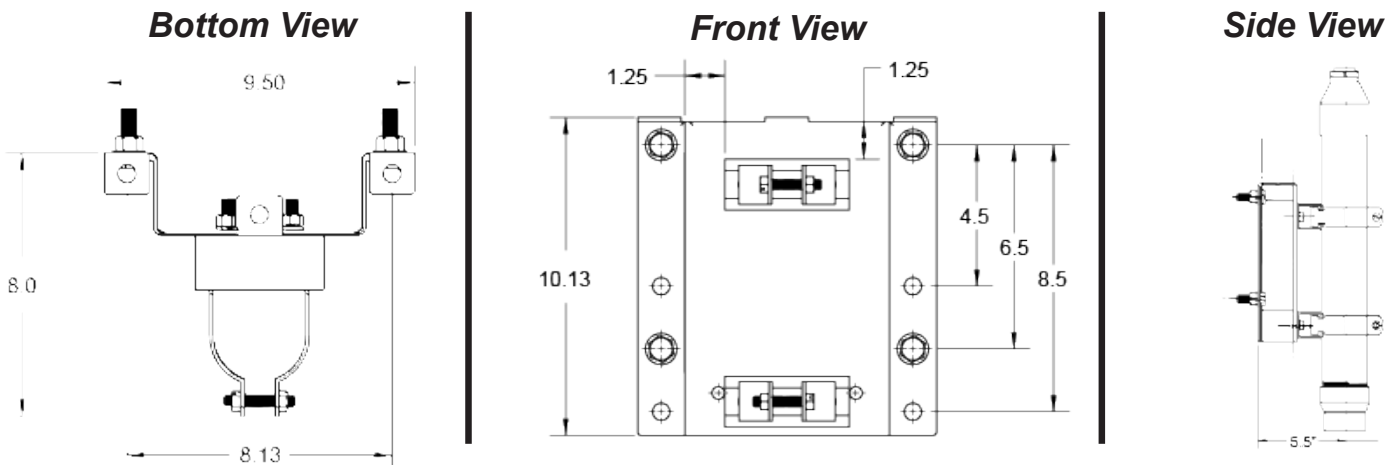

SPECS

Furnish and install Model P-RMB Universal Roof Hydrant Mounting Bracket manufactured by PRIER Products. Bracket must be manufactured of heavy gauge powder coated steel. This bracket is to be installed inside the structure and must have a single penetration through the roof. This bracket must allow for adjustment to meet roof angles up to 2/12 pitch and secure pipes either 1" or 2 1/2". It also must connect to I-beams, steel, truss, wood or concrete with standard construction materials. The roof penetration is to be sealed by the roofing contractor in accordance with roofing codes and conditions in their municipality.