

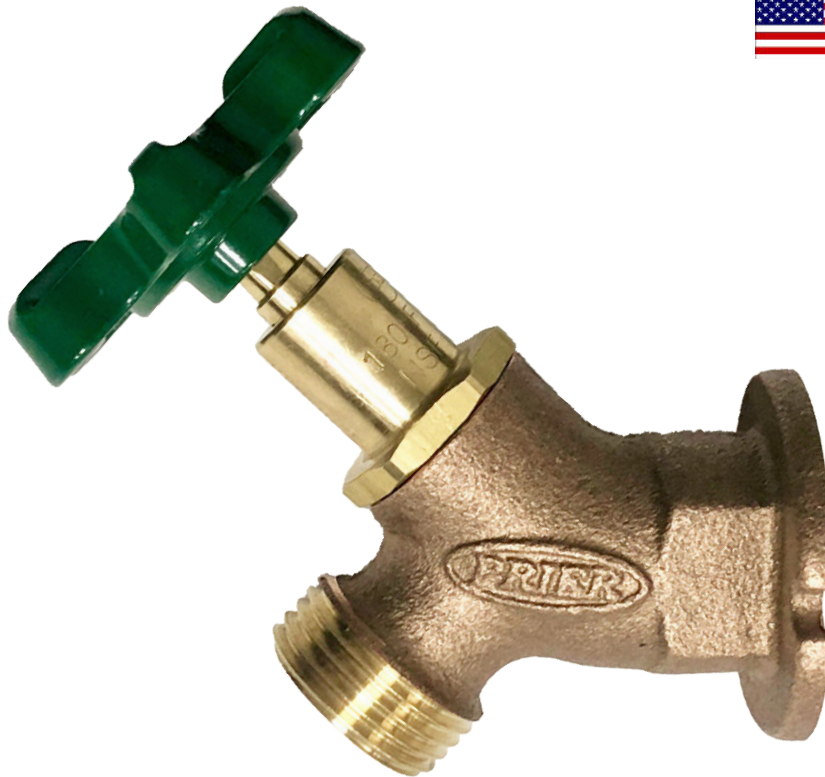

Build With Purpose

# 34-LF Series Heavy Pattern Brass Sillcocks



## Lead Free 34 Series

### FEATURES

- Made from lead free brass and certified to NSF 372
- ASSE 1011 certified for sillcocks with internal vacuum breaker only
- Solid brass operating stem
- Per ASSE 1019, pressure rated to 125 PSI, temperature to 180°
- Large unobstructed waterways for greater flow rates
- Cast metal handle assembly with brass mounting screw
- Green standard handle with red or blue options
- EPDM seals for longer wear life
- Available with added built-in protection from internal vacuum breaker and backflow preventer
- FPT, MPT, and SWT inlet connections
- 3/4" garden hose connection outlet
- Solid brass fast-travel stem with ACME threads
- Each valve individually tested
- Angle of outlet prevents kinks in hose

### ORDERING

34.40LF-\_\_\_\_-B

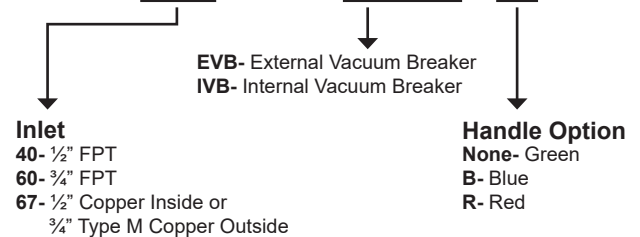

4515 E. 139th Street Grandview, MO 64030 | (800) 362-9055 | PRIER.com

\*Per ASSE 1011 Code, it is not recommended to leave on for more than 12 continuous hours.



Build With Purpose

# 34-LF SERIES REPLACEMENT PARTS

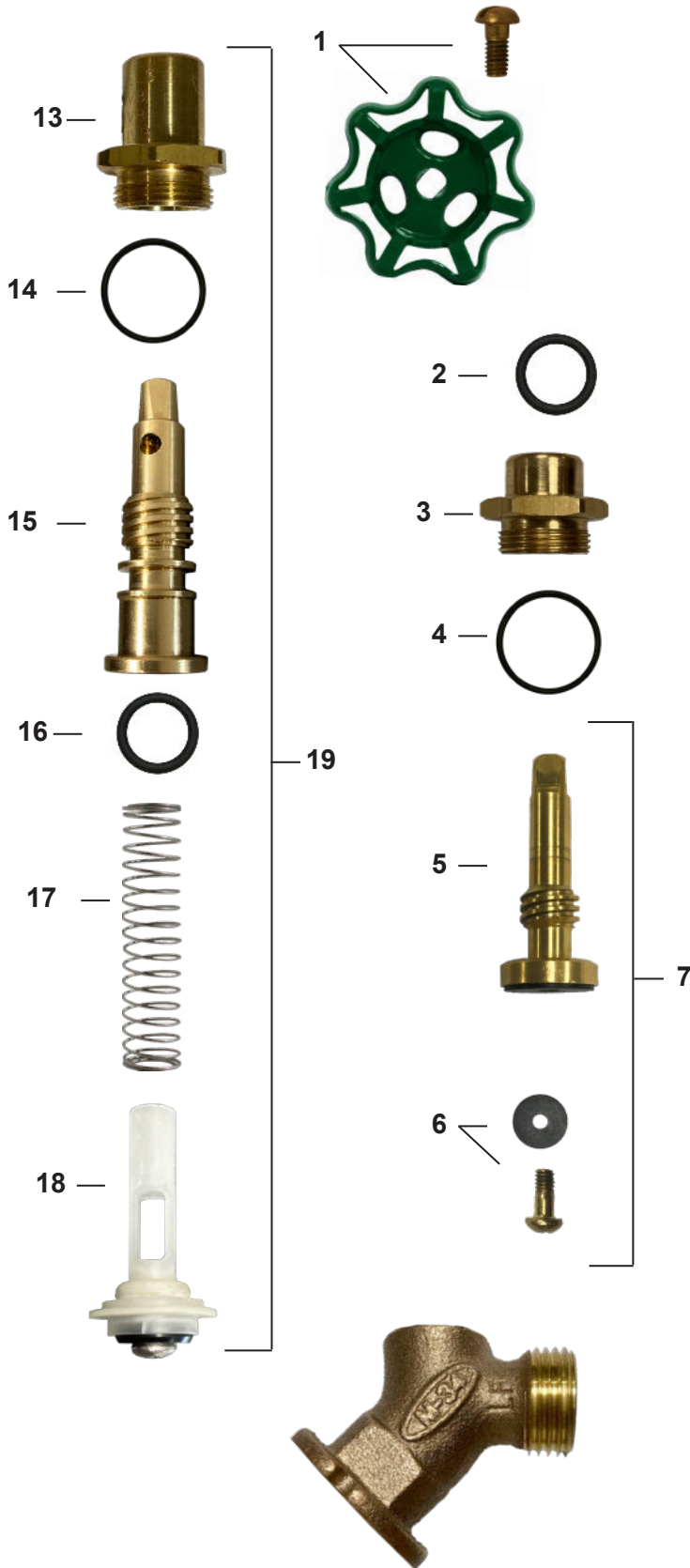

ID	Part No.	Description
1	630-0045	Handle and Screw Kit
2	336-0036	O-Ring
3	310-3117	Valve Stem Cap
4	936-3003	O-Ring
5	310-3019	Stem Body
6	630-0049	Bibb Washer and Screw Kit
7	M-231-3301	Stem Assembly Complete
8		VB Washer
9		Spring
10		Stop and Waste
11		Washer
12		Hose Piece with VB Holes
13	310-3118	IVB Stem Cap
14	937-3003	O-Ring
15	310-3120	IVB Stem Body
16	310-0037	IVB Stem O-Ring
17	324-3100	IVB Spring
18	232-0002	Poppet Assembly
19	231-3302	IVB Stem Assemble Complete
	630-0050	Service Kit for Brass Sillcocks, Contains: 1, 2, 4, 6
	630-0051	Service Kit for IVB Sillcocks, Contains: 1, 14, 16, 17, 18
	630-0048	Vacuum Breaker, Contains: 8, 9, 10, 11, 12

