

**OLD STYLE**  
**Manufactured 1972-April 2013**

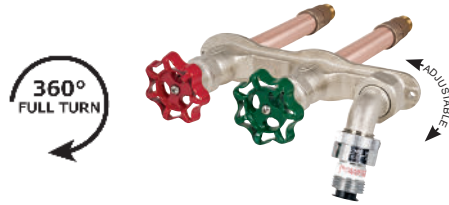

4515 East 139th Street  
 Grandview, MO 64030  
 (800) 362-9055  
 Fax (800) 362-1463  
 www.PRIER.com

## C-108/208 Hot & Cold Wall Hydrant



- Freezeless
- Hot & Cold Mixing
- Anti-Siphon



Replacement Parts and Stems

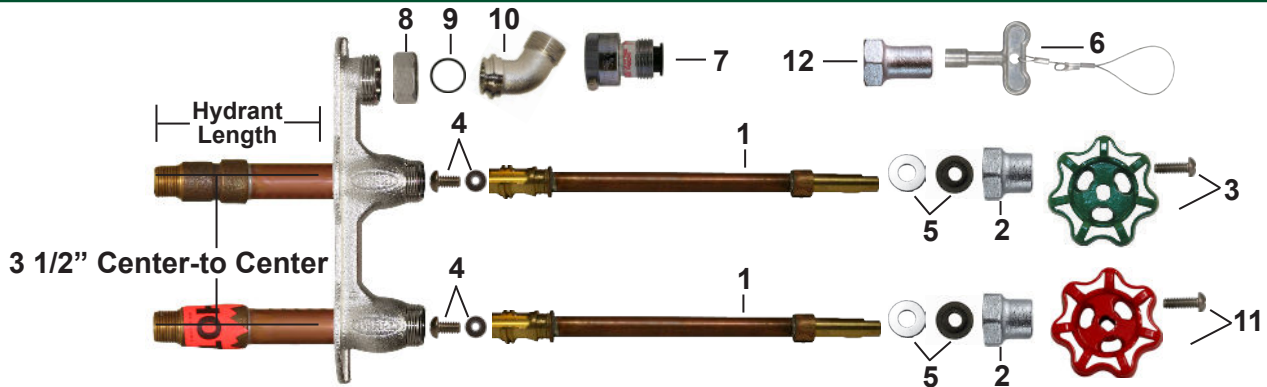

| ID | Part No.    | Description                   | ID | Part No.    | Description                                  |
|----|-------------|-------------------------------|----|-------------|--|
| 1  | See Below   | Stem Assembly, Contains: 1, 4 | 8  | 300-0030    | Hose Thread Nut                              |
| 2  | 300-1008    | Valve Stem Cap                | 9  | 336-0005    | O-Ring for Hose Thread Adapter               |
| 3  | C-134KT-805 | Oval Handle and Screw Kit     | 10 | 300-0029    | Hose Thread Adapter                          |
| 4  | C-134KT-802 | Seat Washer Kit (00 Beveled)  | 11 | C-108KT-805 | Red Handle and Screw Kit                     |
| 5  | C-134KT-803 | Stem Packing Kit              | 12 | 310-1015    | Loose Key Valve Stem Cap                     |
| 6  | C-108KT-808 | Loose Key on Lanyard          |    | C-134KT-804 | Loose Key Conversion Kit, Contains: 5, 6, 12 |
| 7  | P-003NP     | Replacement Vacuum Breaker    |    |             |  |



**E Style Manufactured 1972 - April 2013**

| Part No.   | Style | Stem Length                                  | Description                                   |
|------------|-------|--|---|
| P-231-02CC | E     | 5 <sup>11</sup> / <sub>32</sub> " OAL        | Close Coupled Stem for C-108 Hydrant          |
| P-231-0204 | E     | 7 <sup>19</sup> / <sub>32</sub> " OAL        | Stem for C-108 Hydrant                        |
| P-231-0206 | E     | 9 <sup>19</sup> / <sub>32</sub> " OAL        | Stem for C-108 Hydrant                        |
| P-231-0208 | E     | 11 <sup>19</sup> / <sub>32</sub> " OAL       | Stem for C-108 Hydrant                        |
| P-231-0210 | E     | 13 <sup>19</sup> / <sub>32</sub> " OAL       | Stem for C-108 Hydrant                        |
| P-231-0212 | E     | 15 <sup>19</sup> / <sub>32</sub> " OAL       | Stem for C-108 Hydrant                        |
| P-231-0214 | E     | 17 <sup>19</sup> / <sub>32</sub> " OAL       | Stem for C-108 Hydrant                        |
| P-231-0216 | E     | 19 <sup>19</sup> / <sub>32</sub> " OAL       | Stem for C-108 Hydrant                        |
| P-231-0218 | E     | 21 <sup>19</sup> / <sub>32</sub> " OAL       | Stem for C-108 Hydrant                        |
| P-231-0220 | E     | 23 <sup>19</sup> / <sub>32</sub> " OAL       | Stem for C-108 Hydrant                        |
| P-231-0222 | E     | 25 <sup>19</sup> / <sub>32</sub> " OAL       | Stem for C-108 Hydrant                        |
| P-231-0224 | E     | 27 <sup>19</sup> / <sub>32</sub> " OAL       | Stem for C-108 Hydrant                        |
| P-231-02US | E     | Up to 16 <sup>19</sup> / <sub>32</sub> " OAL | *Universal Replacement Stem for C-108 Hydrant |

PRIER Universal Stems are replacement stems for any size from Close Coupled to 14". They require cutting the rod to proper length and soldering the brass stem end to the rod as directed in instructions.